

19. Exploded View and Replacement Parts List

19.1 WH-MDF09C3E8 WH-MDF12C9E8 WH-MDF14C9E8 WH-MDF16C9E8 (WH-MDF09C3E8-1 WH-MDF12C9E8-1 WH-MDF14C9E8-1 WH-MDF16C9E8-1) (Refrigerant System)

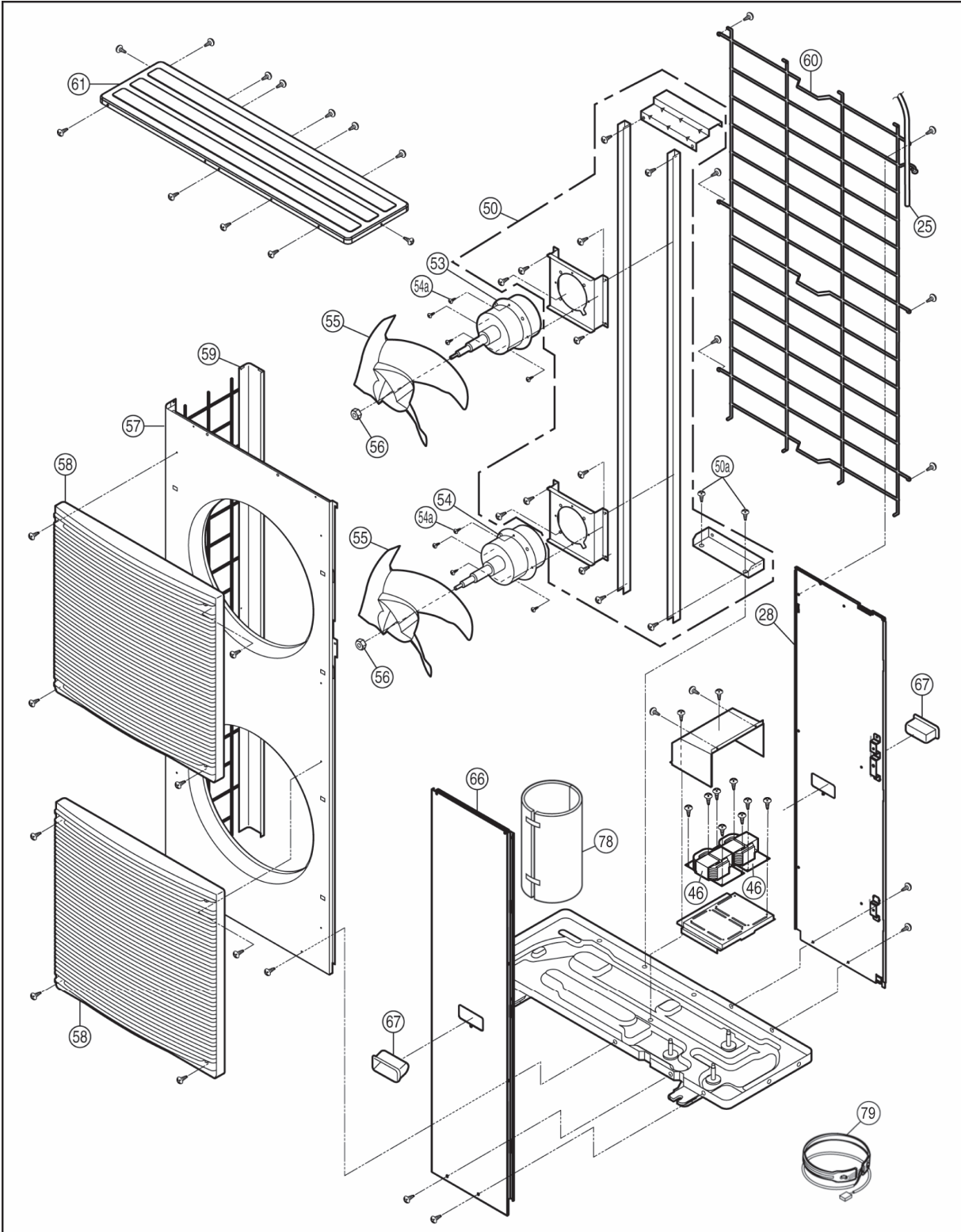

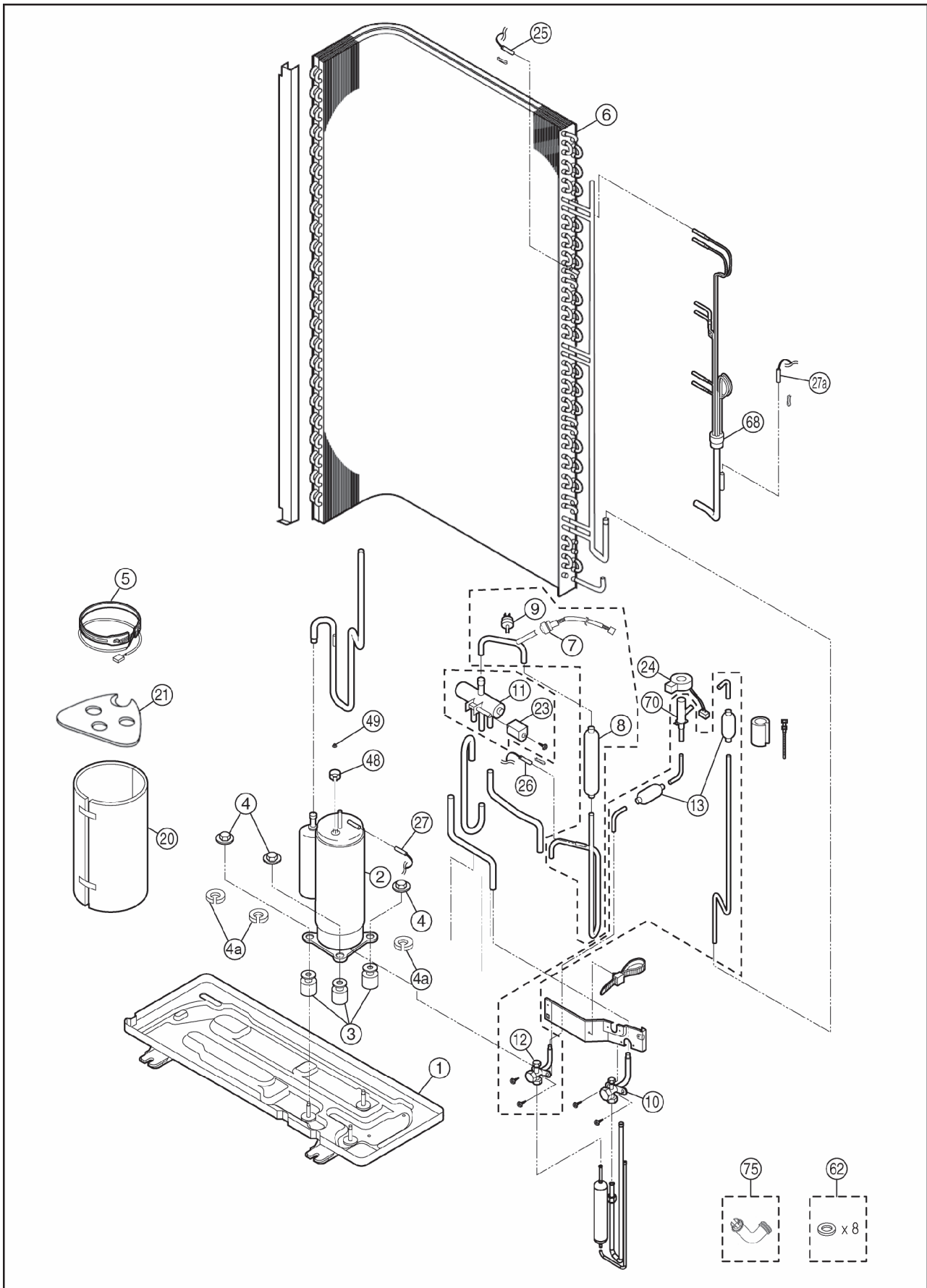

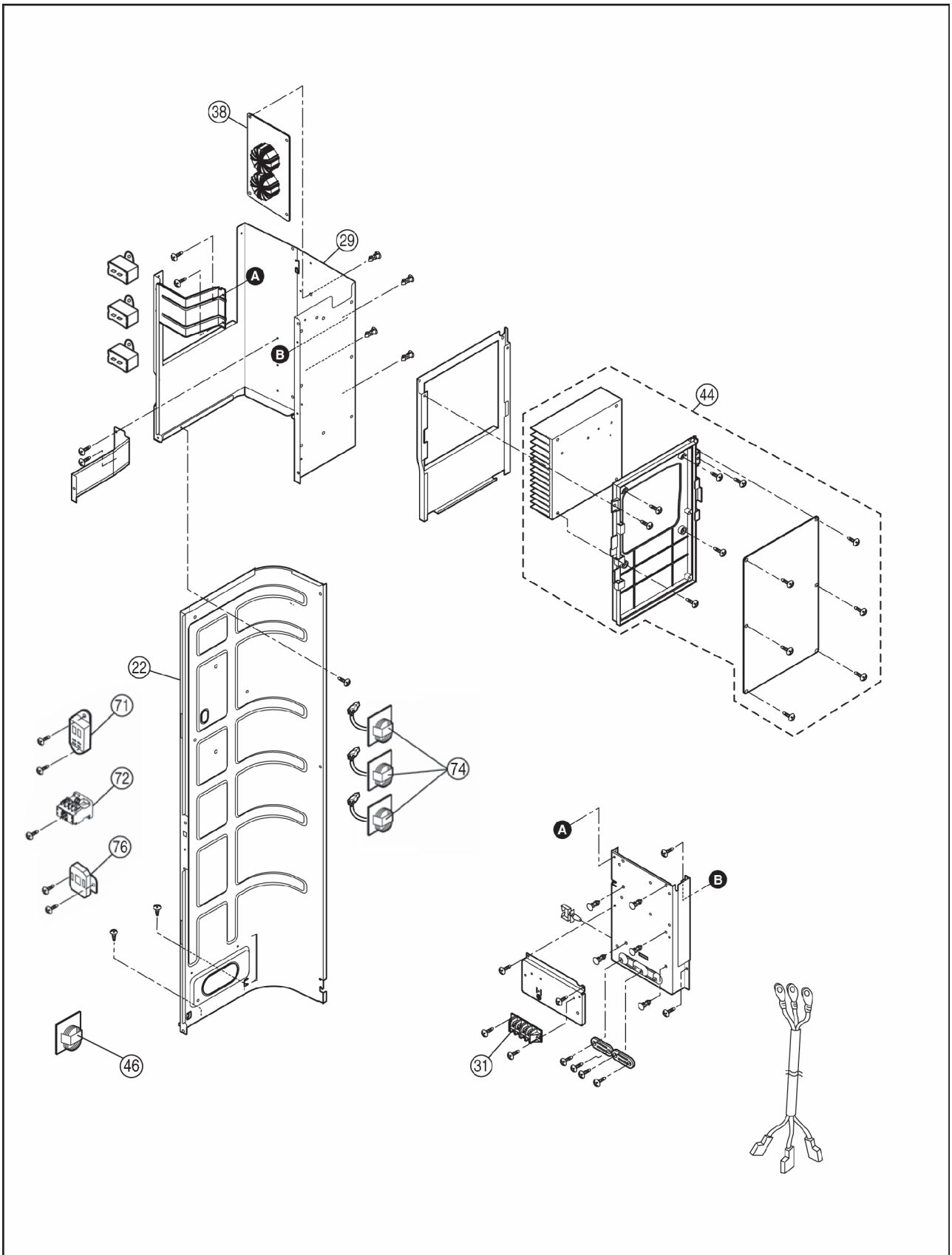

Note:
 The above exploded view is for the purpose of parts disassembly and replacement.
 The non-numbered parts are not kept as standard service parts.

<Model: Refrigerant System>

REF. NO.	DESCRIPTION & NAME	QTY.	WH-MDF09C3E8 (WH-MDF09C3E8-1)	WH-MDF12C9E8 (WH-MDF12C9E8-1)	WH-MDF14C9E8 (WH-MDF14C9E8-1)	WH-MDF16C9E8 (WH-MDF16C9E8-1)	REMARKS
1	BASE PAN ASS'Y	1	CWD52K1276	←	←	←	
2	COMPRESSOR	1	5JD420XBA22	←	←	←	O
3	BUSHING - COMPRESSOR MOUNT	3	CWH50055	←	←	←	
4	NUT-COMPRESSOR MOUNT	3	CWH561049	←	←	←	
4a	GASKET FOR TERMINAL COVER	3	CWB811017	←	←	←	
5	CRANKCASE HEATER	1	CWA341053	←	←	←	
6	CONDENSER COMPLETE	1	CWB32C3035	←	←	←	
7	HIGH PRESSURE SENSOR	1	CWA50C2570	←	←	←	
8	DISCHARGE MUFFLER	1	CWB121014	←	←	←	
9	PRESSURE SWITCH	1	CWA101013	←	←	←	
10	3-WAYS VALVE (GAS)	1	CWB011700	←	←	←	
11	4-WAYS VALVE	1	CWB001046	←	←	←	
12	3-WAYS VALVE(LIQUID)	1	CWB011699	←	←	←	
13	STRAINER	2	CWB111032	←	←	←	
20	SOUND PROOF MATERIAL	1	CWG302265	←	←	←	
21	SOUND PROOF MATERIAL	1	CWG302266	←	←	←	
22	SOUND PROOF BOARD	1	CWH15K1031	←	←	←	
23	V-COIL COMPLETE - 4-WAY VALVE	1	CWA43C2169J	←	←	←	O
24	V-COIL COMPLETE - EXP.VALVE	1	CWA43C2385	←	←	←	O
25	SENSOR-OD TEMP/ COIL	1	CWA50C2730	←	←	←	
26	SENSOR-COMP.DISCHARGE	1	CWA50C2576	←	←	←	
27	SENSOR-COMP. TOP	1	CWA50C2629	←	←	←	
27a	SENSOR-COMP.DEF	1	CWA50C2577	←	←	←	
28	CABINET REAR PLATE-COMplete	1	CWE02K1019A	←	←	←	
29	CONTROL BOARD CASING	1	CWH10K1049	←	←	←	
31	TERMINAL BOARD ASS'Y	1	CWA28K1214	←	←	←	
38	ELECTRONIC CONTROLLER (NOISE FILTER)	1	CWA745822	←	←	←	O
44	ELECTRONIC CONTROLLER (MAIN)	1	CWA73C6782R	CWA73C6783R	CWA73C6784R	CWA73C6785R	O
46	REACTOR	3	G0C293J00001	←	←	←	
48	TERMINAL COVER	1	CWH171039A	←	←	←	
49	NUT-TERMINAL COVER	1	CWH7080300J	←	←	←	
50	FAN MOTOR BRACKET	1	CWD54K1024	←	←	←	
50a	SCREW-FAN MOTOR BRACKET	8	CWH551040J	←	←	←	
53	FAN MOTOR (UPPER)	1	EHDS83CAC	←	←	←	O
54	FAN MOTOR (BOTTOM)	1	EHDS83DAC	←	←	←	O
54a	SCREW-FAN MOTOR MOUNT	8	CWH551323	←	←	←	
55	PROPELLER FAN ASSY	2	CWH00K1006	←	←	←	
56	NUT-PROPELLER FAN	2	CWH561092	←	←	←	
57	CABINET FRONT PLATE	1	CWE061098A	←	←	←	
58	DISCHARGE GRILLE	2	CWE201073	←	←	←	
59	CABINET SIDE PLATE ASSY	1	CWE04K1023A	←	←	←	
60	WIRE NET	1	CWD041103A	←	←	←	
61	CABINET TOP PLATE	1	CWE03C1105	←	←	←	
62	ACCESSORY-COMplete	1	CWH82C1839	←	←	←	
66	CABINET FRONT PLATE	1	CWE061274A	←	←	←	
67	HANDLE	2	CWE161014	←	←	←	
68	TUBE ASSY (CAP.TUBE)	1	CWT07K1541	←	←	←	
70	EXPANSION VALVE	1	CWB051028	←	←	←	
71	ELECTRO MAGNETIC SWITCH	1	K6C2AGA00002	←	←	←	
72	ELECTRO MAGNETIC SWITCH	1	K6C4E8A00001	←	←	←	

REF. NO.	DESCRIPTION & NAME	QTY.	WH-MDF09C3E8 (WH-MDF09C3E8-1)	WH-MDF12C9E8 (WH-MDF12C9E8-1)	WH-MDF14C9E8 (WH-MDF14C9E8-1)	WH-MDF16C9E8 (WH-MDF16C9E8-1)	REMARKS
74	REACTOR	3	G0C153J00009	←	←	←	
75	ACCESSORY CO.(DRAIN ELBOW)	1	CWG87C2030	←	←	←	
76	PTC THERMISTOR	1	D4DDG1010001	←	←	←	
78	SOUND PROOF MATERIAL	1	CWG302599	←	←	←	
79	CRANKCASE HEATER (BASE PAN)	1	CWA341071	←	←	←	

Note:

- All parts are supplied from PAPAMY, Malaysia (Vendor Code: 00029488).
- "O" marked parts are recommended to be kept in stock.

**19.2 WH-MDF09C3E8 WH-MDF12C9E8 WH-MDF14C9E8 WH-MDF16C9E8
(WH-MDF09C3E8-1 WH-MDF12C9E8-1 WH-MDF14C9E8-1
WH-MDF16C9E8-1)
(Water System)**

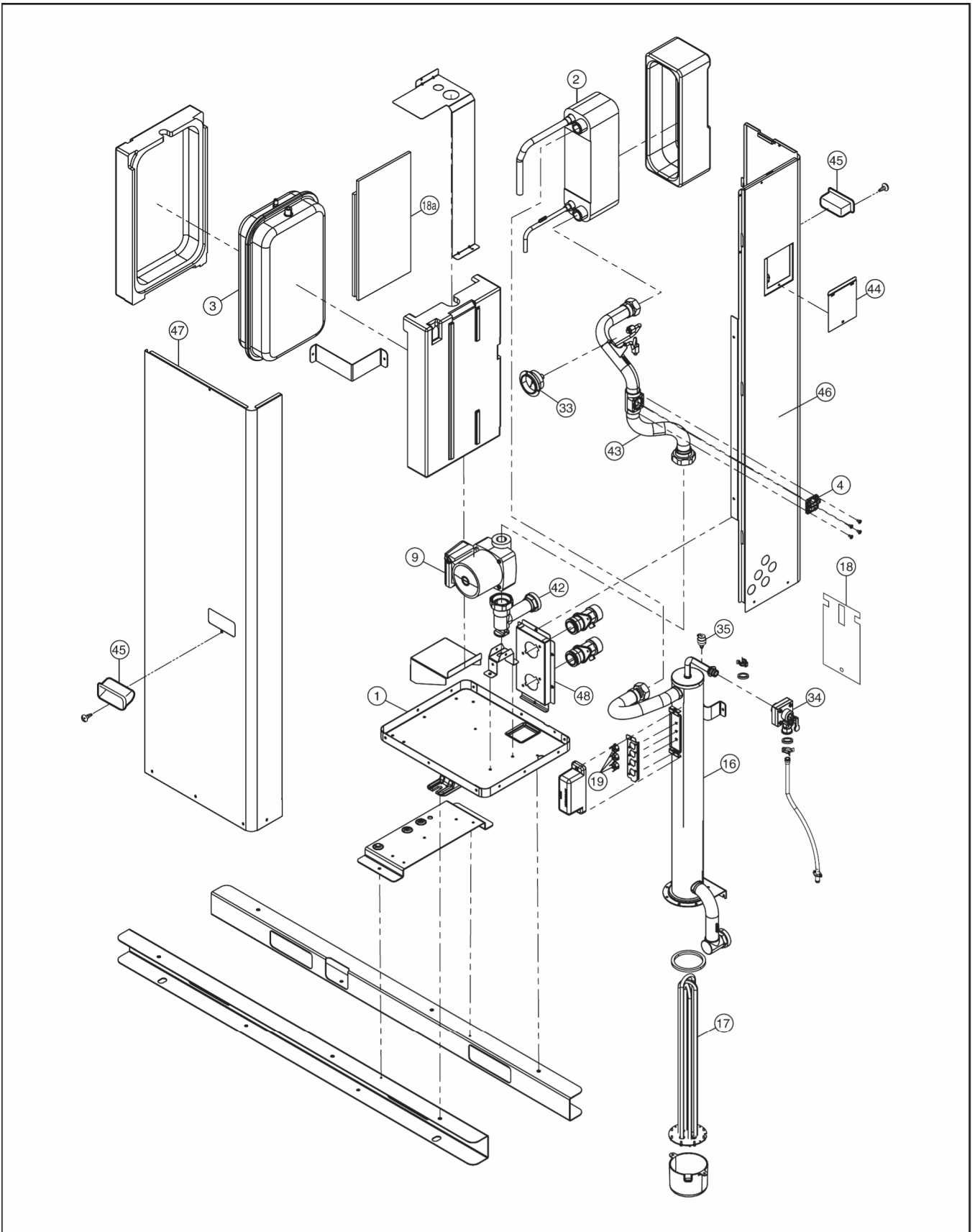

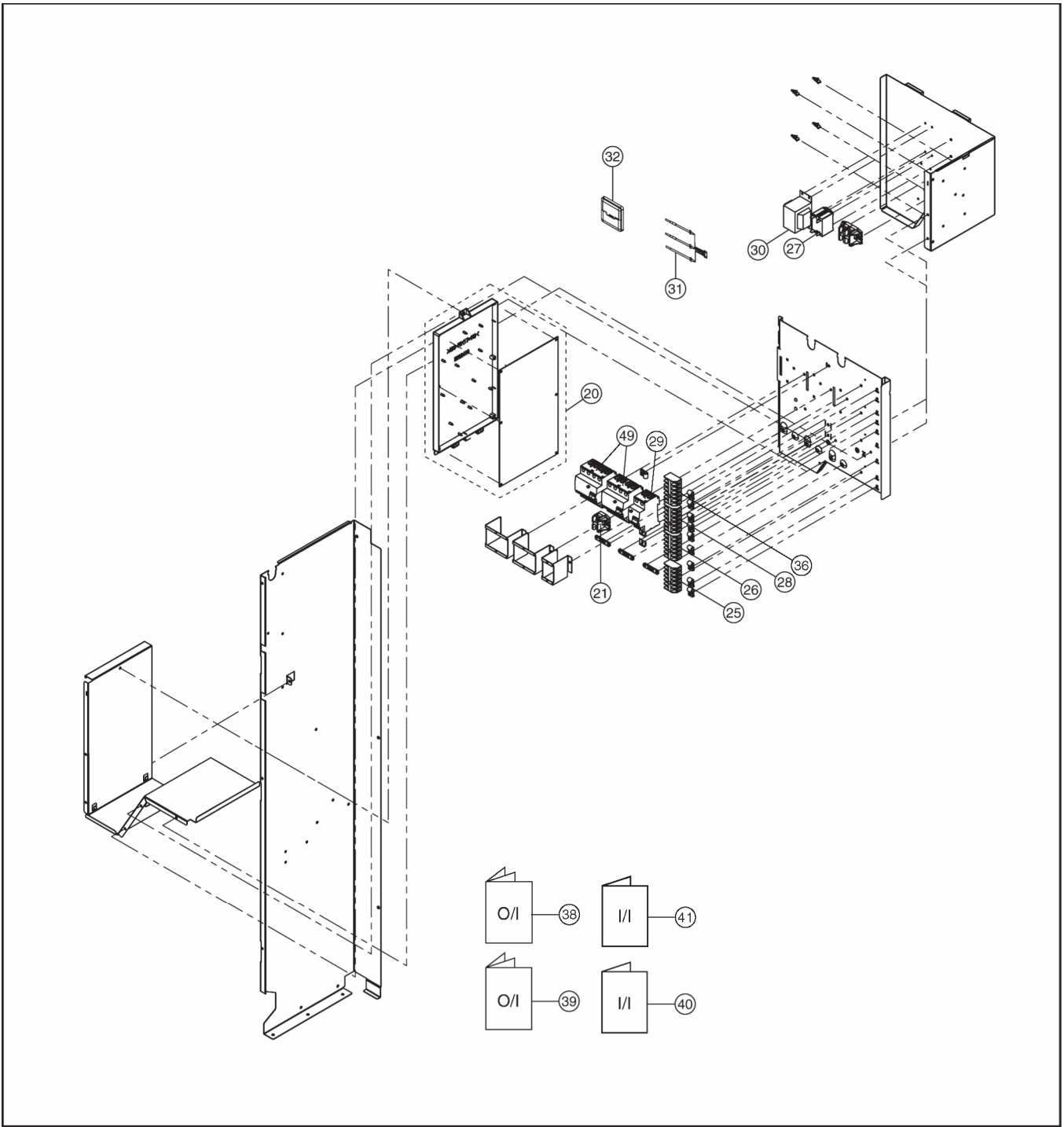

Note:
 The above exploded view is for the purpose of parts disassembly and replacement.
 The non-numbered parts are not kept as standard service parts.

<Model: Water System>

REF. NO.	DESCRIPTION & NAME	QTY.	WH-MDF09C3E8 (WH-MDF09C3E8-1)	WH-MDF12C9E8 (WH-MDF12C9E8-1)	WH-MDF14C9E8 (WH-MDF14C9E8-1)	WH-MDF16C9E8 (WH-MDF16C9E8-1)	REMARKS
1	BASE PAN ASS'Y	1	CWD52K1242	←	←	←	
2	HOT WATER COIL-COMplete	1	CWB90C1046	←	←	←	O
3	RECEIVER	1	CWB141039	←	←	←	
4	FLOAT (FLOW SWITCH)	1	CWB601008	←	←	←	O
9	PUMP	1	CWB532096	←	←	←	O
16	BOTTLE COMP.	1	CWH90C0033	←	←	←	
17	HEATER ASS'Y	1	CWA34K1029	CWA34K1030	←	←	O
18	SOUND PROOF MATERIAL	1	CWG302592	←	←	←	
18a	SOUND PROOF MATERIAL	1	CWG302594	←	←	←	
19	THERMOSTAT	4	CWA151065	←	←	←	O
20	ELECTRONIC CONTROLLER (MAIN)	1	CWA73C6741R	CWA73C6742R	CWA73C6743R	CWA73C6744R	O
21	TERMINAL BOARD ASS'Y	1	CWA28K1200	←	←	←	
25	TERMINAL BOARD ASS'Y	1	CWA28K1211	←	←	←	
26	TERMINAL BOARD ASS'Y	1	CWA28K1221	←	←	←	
27	ELECTRO MAGNETIC SWITCH	1	K6C1AYY00004	←	←	←	
28	TERMINAL BOARD ASS'Y	1	CWA28K1222	←	←	←	
29	CIRCUIT BREAKER	1	CWA181005	←	←	←	O
30	TRANSFORMER-COMplete	1	CWA40C1096	←	←	←	O
31	SENSOR-COMplete	1	CWA50C2749	←	←	←	O
32	REMOTE CONTROL COMPLETE	1	CWA75C4024	←	←	←	O
33	PRESSURE GAUGE	1	CWB070001	←	←	←	O
34	PRESSURE RELIEF VALVE	1	CWB621092	←	←	←	O
35	PRESSURE RELIEF VALVE	1	CWB621094	←	←	←	
36	TERMINAL BOARD ASS'Y	1	CWA28K1232	←	←	←	
38	OPERATING INSTRUCTION	1	CWF568652	←	←	←	
39	OPERATING INSTRUCTION	1	CWF568660	←	←	←	
40	INSTALLATION INSTRUCTION	1	CWF615446	←	←	←	
41	INSTALLATION INSTRUCTION	1	CWF615447	←	←	←	
42	TUBE CONNECTOR-COMplete	1	CWT29C1050	←	←	←	
43	TUBE CONNECTOR-COMplete	1	CWT29C1064	←	←	←	
44	CONTROL BOARD COVER	1	CWH131420A	←	←	←	
45	HANDLE	2	CWE161014	←	←	←	
46	CABINET SIDE PLATE ASS'Y	1	CWE04K1060A	←	←	←	
47	CABINET FRONT PLATE	1	CWE061275A	←	←	←	
48	HOLDER COUPLING	1	CWH351181A	←	←	←	
49	CIRCUIT BREAKER	2	CWA181008	←	←	←	

Note:

- All parts are supplied from PAPAMY, Malaysia (Vendor Code: 00029488).
- "O" marked parts are recommended to be kept in stock.